

ROCKIT[®]

COMPLETE RAIL-LESS RACKING SYSTEM

INSTALLATION GUIDE

REVISION DATE: 11/20/25

VERSION: v4.3



Clicking the page name will take you to that page

TABLE OF CONTENTS **PAGE 01**

FEATURES & BENEFITS **PAGE 02**

SYSTEM SPECIFICATIONS **PAGE 03**

COMPONENTS **PAGE 04**

RATINGS **PAGE 06**

PLACEMENT **PAGE 07**

INSTALLATION **PAGE 09**

SUPPLEMENTAL GUIDES **PAGE 18**

METAL ROOFS **PAGE 19**

GROUNDING **PAGE 20**

COMPATIBLE MODULES **PAGE 22**

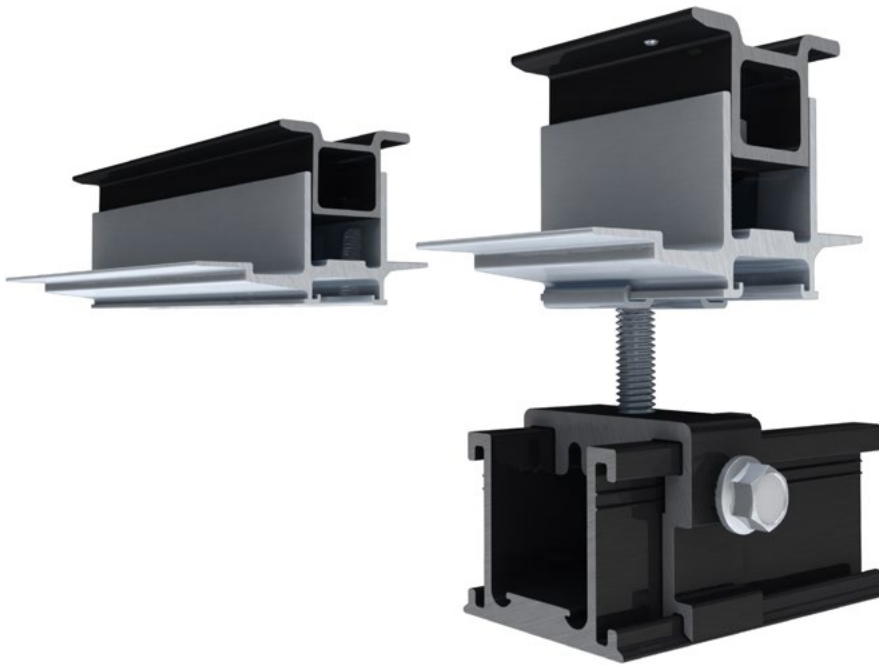

ROCKIT

The RockIt system conforms to UL 2703 (and UL 2703A when using the Rockit Smart Slide) and is the industry's premier rail-less PV racking system for composition shingle, tile, and metal pitched and flat rooftops. Designed in conjunction with installers, RockIt quickly & easily installs with a single tool. It features an easy-to-position mount alignment and a top-down leveling system.

RockIt is logistically intelligent with no need to ship or transport long rails.

Components are available in a black finish that compliments both commercial and residential applications.

FEATURES

- Patented Watertight Technology
- Fully integrated bonding
- Top-down leveling system
- North-South adjustability
- Single tool install

DISCLAIMER

This manual describes proper installation procedures and provides necessary standards required for product reliability. Warranty details are available on the website. All installers must thoroughly read this manual and have a clear understanding of the installation procedures prior to installation. Failure to follow these guidelines may result in property damage, bodily injury or even death.

IT IS THE INSTALLER'S RESPONSIBILITY TO:

- Ensure safe installation of all electrical aspects of the array. All electrical installation and procedures should be conducted by a licensed and bonded electrician or solar contractor.
- All work must comply with national, state and local installation procedures, product and safety standards, including the proper use of PPE.
- Comply with all applicable local or national building and fire codes, including any that may supersede this manual.
- Ensure all products are appropriate for the installation, environment, and array under the site's loading conditions.
- Use only EcoFasten parts or parts recommended by EcoFasten; substituting parts may void any applicable warranty.
- Review the Design Assistant and Certification Letters to confirm design specifications.
- Ensure provided information is accurate. Issues resulting from inaccurate information are the installer's responsibility.
- Ensure bare copper grounding wire does not contact aluminum and zinc-plated steel components, to prevent risk of galvanic corrosion.
- If loose components or loose fasteners are found during periodic inspection, re-tighten immediately. Any components showing signs of corrosion or damage that compromise safety shall be replaced immediately.
- Provide an appropriate method of direct-to-earth grounding according to the latest edition of the National Electrical
- Code, including NEC 250: Grounding and Bonding, and NEC 690: Solar Photovoltaic Systems.
- Disconnect AC power before servicing or removing modules, AC modules, microinverters and power optimizers.
- Review module and any 3rd party manufacturer's documentation for compatibility and compliance with warranty terms and conditions.
- Ensure that the roof is in good condition prior to installing any EcoFasten components.

ROCKIT

INSTALLATION GUIDE

**EcoFasten**

For Installers. By Installers.

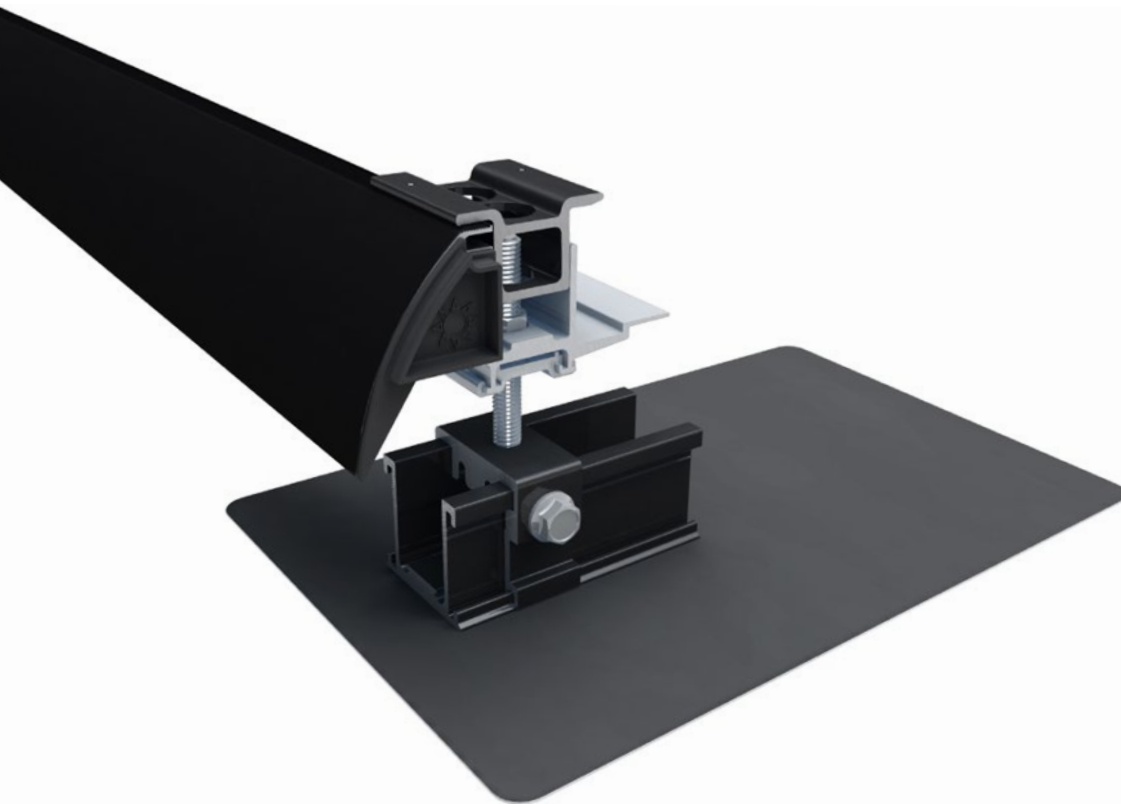
**ROCKIT SYSTEM SPECIFICATIONS**

Leveling Range	3.25" - 4.5" above the roof	Materials	300 series stainless steel, 6000 series aluminum
North-South Slide Range	Slide dependent 3-7 inches	Finish	Black anodization/Mill finish
Warranty	25 year material and workmanship		

TOOL LIST

Comp Slide & Flashings <ul style="list-style-type: none"> • 7/32" Drill bit • 1/2" Deep-well socket (not thick wall impact) • Chalk line • String line (optional) 	Smart Slide <ul style="list-style-type: none"> • 1/2" Deep-well socket (not thick wall impact) • 5/16" Nutdriver for impact with 2" extension • Chalk line • String line (optional)
--	--

PLEASE NOTE: Review module and any third-party manufacturer's documentation for compatibility and compliance with warranty terms and conditions.

SYSTEM SPECS

REQUIRED SYSTEM COMPONENTS
ROCKIT SYSTEM



MOUNT



COUPLING



SKIRT &
END CAP

COMP SHINGLE INSTALLATION
COMP SLIDE & FLASHING



COMP SLIDE



GF-1 FLASHING



LAG SCREW

COMP SHINGLE INSTALLATION
SMARTSLIDE



SMART SLIDE



SMART SCREW

FLAT ROOF INSTALLATION
COMP SLIDE + SIMPLEGRIP



COMP SLIDE

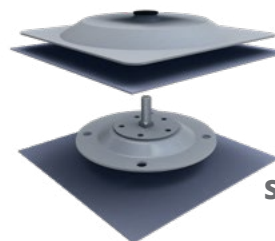

SIMPLEGRIP

COMPONENTS

STANDING SEAM ROOF INSTALLATION
COMP SLIDE & SIMPLEBLOCK-U



COMP SLIDE



SIMPLEBLOCK-U

OPTIONAL ACCESSORIES
EBOS & WIRE MANAGEMENT



JUNCTION BOX



SMART CONDUIT MOUNT



FRAME MLPE MOUNT



MID CLIP



SIDE CLIP



UNIVERSAL SIDE CLIP

COMPONENTS



RATINGS

Fire Ratings	Class A* and B** System Fire Rating
Max System Voltage	1500V
Max Fuse Rating	40A
Certification	Conforms to UL STD 2703 and UL SUBJECT 2703A
Markings	Product listing label is located on RockIt Mount
Roof Pitch	1/4 to 21:12 (1.2 to 60 degrees)
UL 2703 Allowable Design Load Rating	30 psf downward, 30 psf upward and 20 psf lateral
Max Module Size	25.6 sq. ft.
Maximum Cantilever	1/3 of span
Maximum Span	6 ft Landscape, 4 ft Portrait
Multiple use Rated Components (Position Independent)	RockIt Mount, RockIt Coupling & MLPE Module Mount
UL 2703A Smart Slide Ratings	<ul style="list-style-type: none"> • Steep Slope Ratings applicable for Asphalt Shingle roofs with slopes 2:12 and up • Low Slope Ratings applicable for Roll Roofing (Rolled Comp) roofs with slopes 1:12 and up • Low Slope Ratings applicable for Modified Bitumen (Mod-Bit) roofs with slopes 1/4:12 and up

*Class A System fire rating with Steep and Low Slope Roofs and Type 1, 2, 3, 4, 5, 13, 19, 25, 29, 30 and 38 PV modules with no skirt required. Class A System fire rating with Steep Slope Roofs and Type 4 and 5 modules with south edge skirt required. Any roof-to-module gap is permitted. This rating is applicable with any roof attachment.

**Class B System fire rating with Steep Slope Roofs and Type 4 and 5 modules, no skirt required. Any roof-to-module gap is permitted. This rating is applicable with any roof attachment.

***Mounts and couplings cannot be installed on module frames with flanges less than 22mm wide

UL 2703 MARKING EXAMPLE:

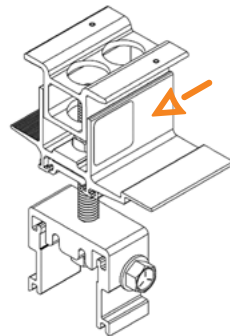

TORQUE SPECIFICATIONS

Component	Torque (in-lb)	Notes
Smart Screws	N/A	Fully Seat. Use visual indicator of the black EPDM ring around the bonded washer for torquing.
Mount	200	
Coupling	200	
Steel Slide Screw	N/A	Fully Seat. Use visual indicator of the black EPDM ring around the bonded washer for torquing.
MLPE Module Mount	144	
Ground Lug	N/A	Refer to specific ground lug manufacturer's installation manual
RockIt Pedestal Screw	150	

System components should be periodically re-inspected for loose components, loose fasteners, and corrosion such that if found, the affected components are to be immediately replaced.

SLIDE PLACEMENT

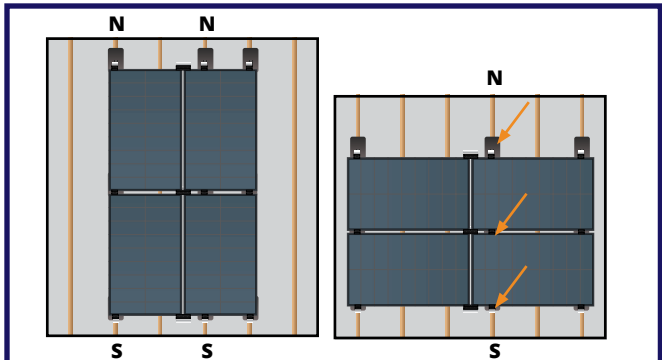

STRUCTURAL ATTACHMENT POINTS

- Find the required structural attachment points.

SLIDE SPACING

- Spacing may vary depending upon project specific structural requirements: i.e. high snow and wind load areas may require lesser bracket spacing in the East-West axis vs. the maximum spacing.
- Max spacing is 48" OC for portrait orientation and 72" OC for landscape orientation.
- Consult project layout diagram for project specific slide spacing on the roof.
- Install slides to predetermined mount spacing.

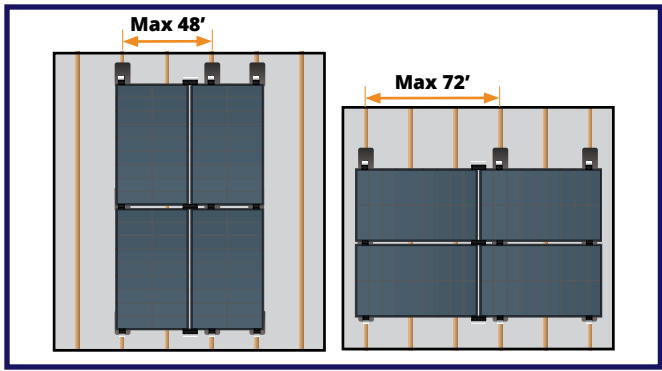

ARRAY SKIRT SECTIONS

- Use the array skirt as a guide to lay out module placement.

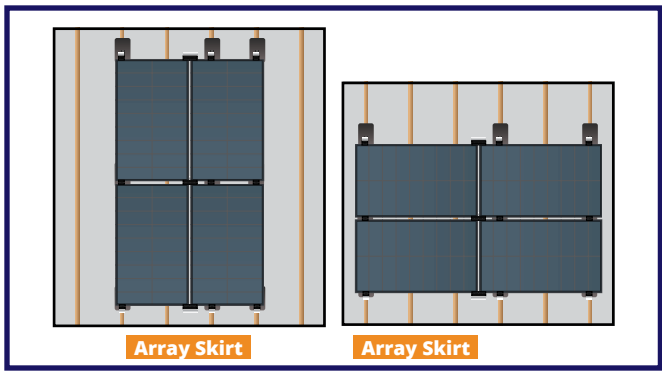

ROW SPACING

- The distance between the rows of mounts is calculated by the module dimension North-South plus 1 5/16".

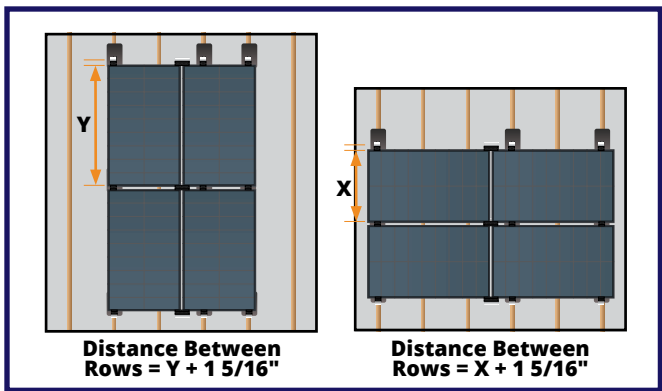

PLACEMENT

SLIDE PLACEMENT

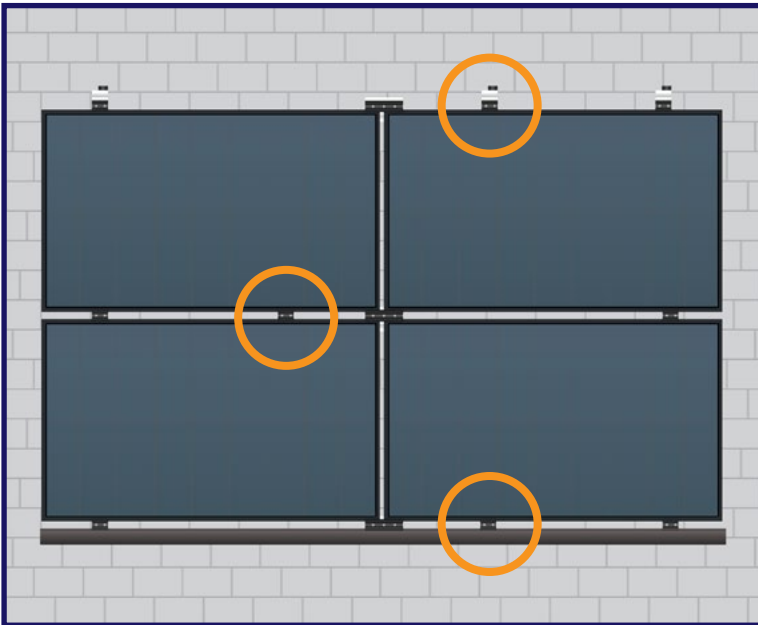

LAYOUT WITH STAGGERED SLIDES

- To reduce the load on an individual rafter, slides can be mounted in a staggered configuration
- Reference each project layout



RockIt Mount



RockIt Coupling

CANTILEVER & OFFSET

- **CANTILEVER:** Maximum cantilever is 1/3 attachment spacing.
- **OFFSET:** Offset from all roof edges depends on wind speed, snow loads, local fire and building codes per location.

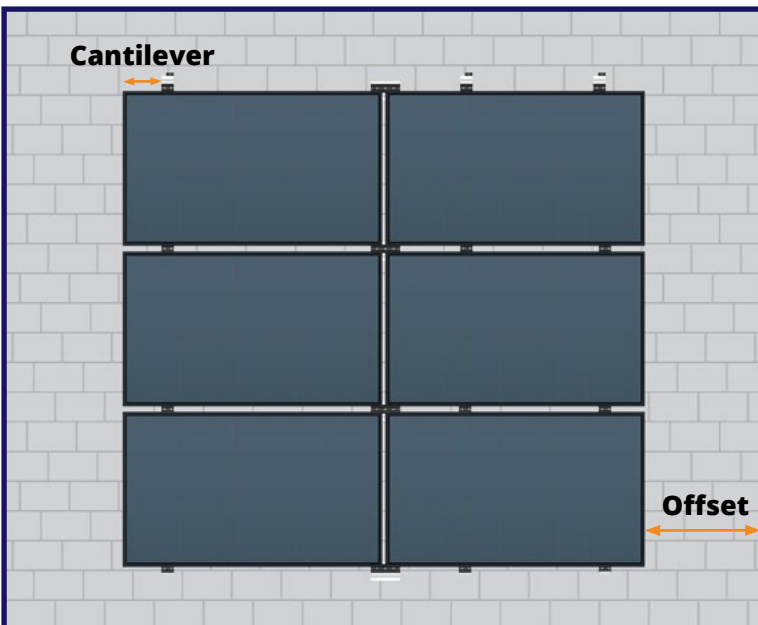

COMP SHINGLE INSTALLATION

COMP SLIDE & FLASHING

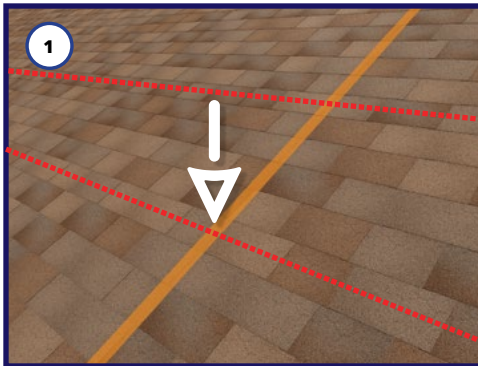

1 SNAP LINES

Snap chalk lines based on module dims + 1 5/16" spacing and then locate rafters

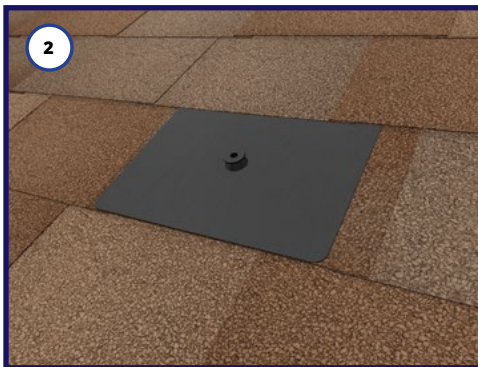

2 PILOT HOLE

Drill a 7/32" pilot hole into the rafter or structural member for the lag screw. Backfill with sealant compatible with the roof type.

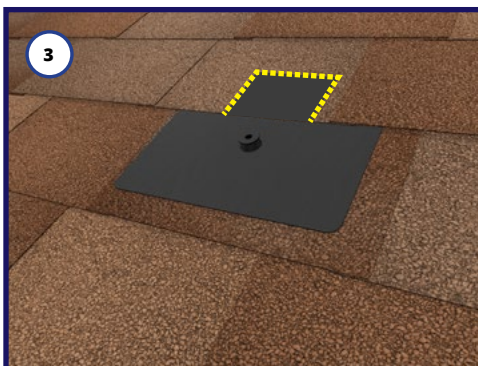

3 CUT SHINGLE (IF NECESSARY)

To position the slide in the correct location, it is acceptable to cut out a portion of the shingle

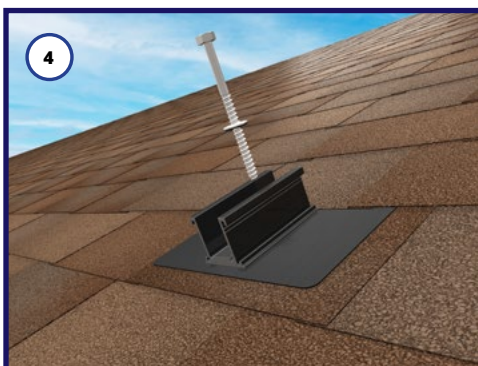

4 INSERT LAG BOLT

- Line up pilot hole with flashing hole.
- Using only the EcoFasten provided lag screw*, insert the lag through the RockIt Comp Slide, the gasketed hole in the flashing and into the rafter. Position the slide with the date stamp facing south.
- Torque: The range is between 100-140 inch-pounds depending on the type of wood and time of year. The visual indicator for proper torque is when the EPDM on the underside of the bonded washer begins to push out the sides as the washer compresses. If using an impact wrench to install the fasteners be careful not to over torque the fastener. You may need to stop and use a ratchet to finish the install.

*** It is important to only use the lag screws provided by EcoFasten because they have longer thread lengths to increase the pull-out force**

COMP SHINGLE INSTALLATION SMART SLIDE

ARRAY POSITIONING

Use the shingle overlap as your starting position to snap your first chalk line (See image below). We recommend snapping chalk lines at every row to make sure every installation is completed with confidence and easy. After chalk lines have been snapped for each row, being as precise as possible, locate the rafters within the array making sure to follow the span chart and cantilevers.

NOTE: For landscape module orientation, the north-south distance between each chalk line is equal to the module width plus 1-5/16". For portrait, the distance is the module length plus 1-5/16".

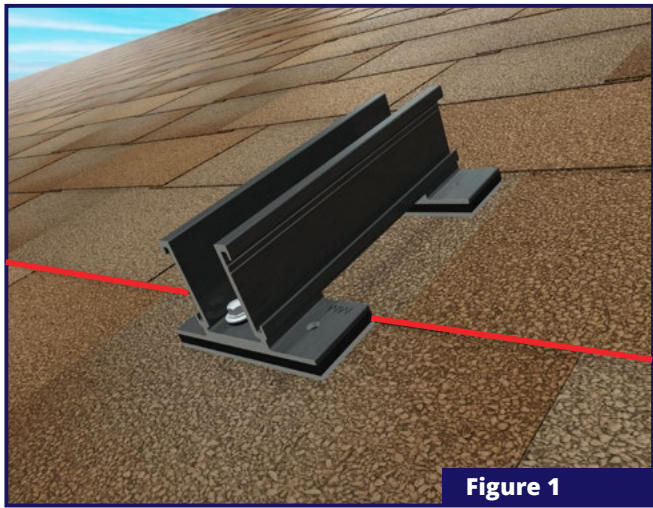

Figure 1

PLACING THE SLIDE

Once the general location of each rafter is marked, clean the mounting location with a nylon brush for proper sealing. Before peeling off the release liners, please note the Smart Slide is designed to straddle the two shingle courses. It is important to make sure the bottom foot is flush and pushed up against the shingle course edge above (see figure 1). When you locate the rafter, peel off the two release liners and place the center of the slide over the rafter.

NOTE: Only install on clean roofs free of snow , ice and debris in ambient temperatures between 5° F and 118° F. If installing on Presidential shingles of rare thickness over 1/8", cut off the shingle tabs to ensure the slide lies flat.

COMP SHINGLE INSTALLATION SMART SLIDE

SCREW PLACEMENT & DRIVING THE SCREWS



NOTE: Once the release liner is removed and the slide is placed into position, it will be difficult to remove from the roof.

Screws should be driven in straight down and square with the base. Use a long nut driver or a drive extension to better view the mounting screws for proper alignment and the sealing washers for correct compression.

NEVER REMOVE A SCREW after it have been driven into the roof, even if it misses a rafter. Smart Slide is designed to give the installer multiple opportunities to find the rafter.

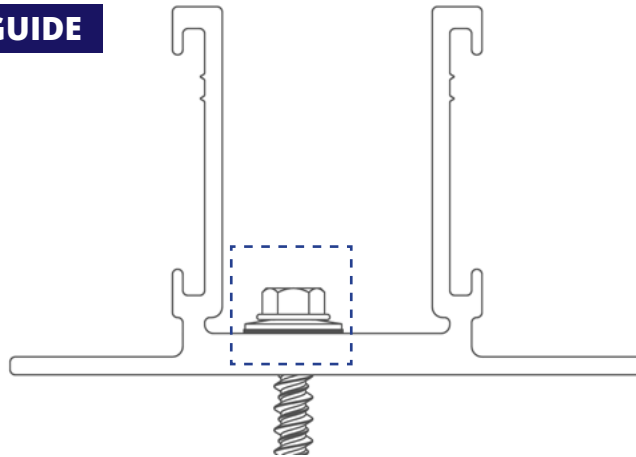
EPDM TORQUE GUIDE

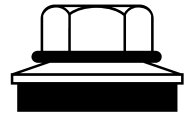

<p>CORRECT</p>  <p>LEVEL</p>	<p>INCORRECT</p>  <p>NOT ENOUGH TORQUE</p>	<p>INCORRECT</p>  <p>TOO MUCH TORQUE*</p>	<p>INCORRECT</p>  <p>TILTED</p>
---	---	--	--

* If too much torque is used it could damage the EPDM washer. Damaged or blown out EPDM washers should be replaced with a new washer as needed.

COMP SHINGLE INSTALLATION SMART SLIDE

SCREW PLACEMENT - DECK MOUNTED INSTALLATION

When installing direct to the roof deck without regard to rafter locations, all 8 screws must be installed. (Be sure to reference the direct to deck span tables.)

SCREW PLACEMENT - RAFTER MOUNTED

1. INSTALLATION - FIRST ATTEMPT

Drive screw in Hole B. If a rafter is hit with the first screw, the second screw can immediately be driven through Hole F. No additional screws are needed if the first 2 screws hit the rafter.

2. INSTALLATION - SECOND ATTEMPT

If the rafter is missed with the first screw as shown below with a red circle, drive a second screw through Hold C. If the rafter is hit with the second screw, the third screw can immediately be driven through Hole G.

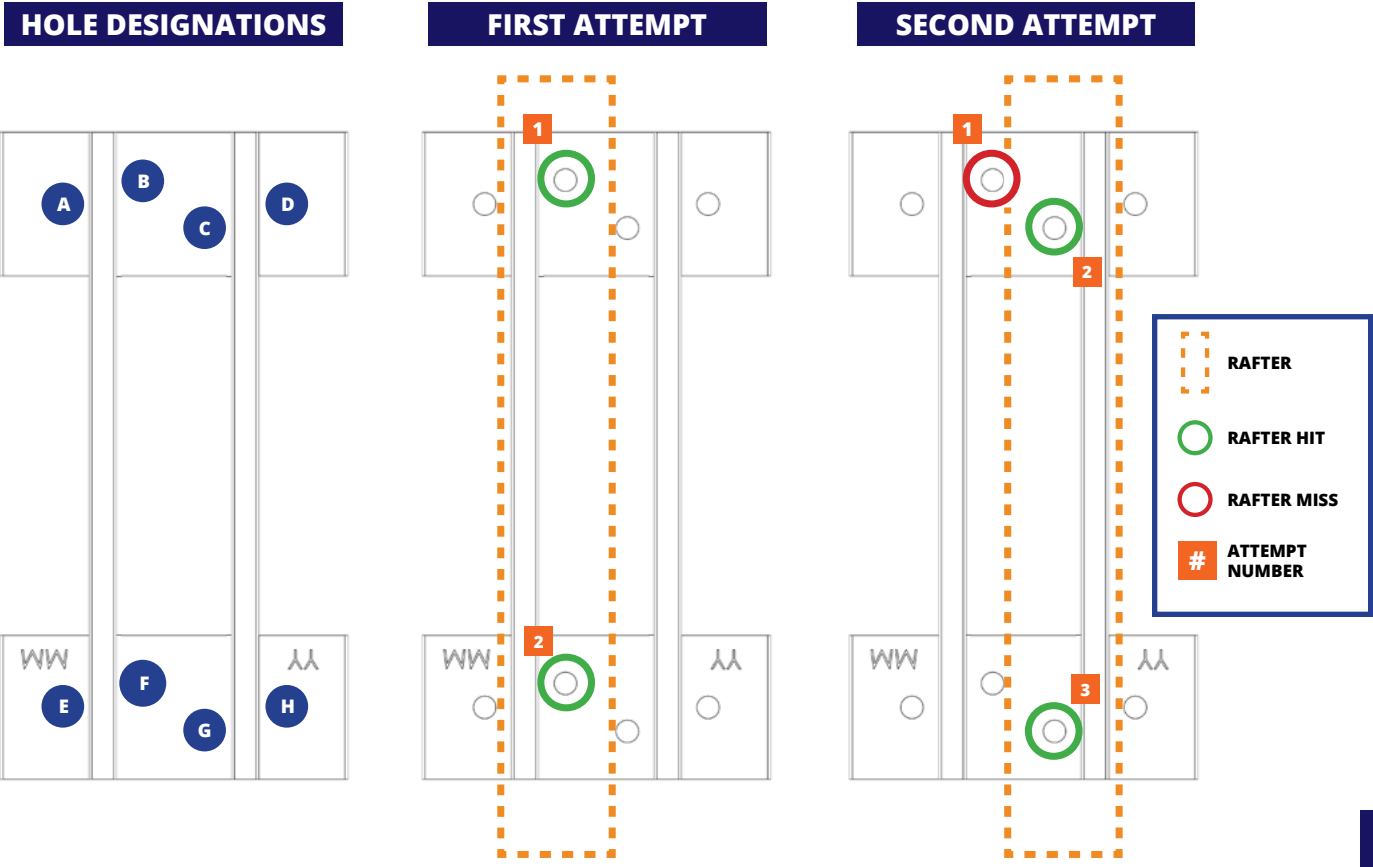

NOTE: If a rafter is missed completely within the slide, you must add another slide to the previous rafter.

INSTALLATION



COMP SHINGLE INSTALLATION SMART SLIDE

SCREW PLACEMENT

3. INSTALLATION - THIRD ATTEMPT

If the rafter is missed in both Holes B & C, then try Hole A and Hole D. If a rafter is hit through either of those holes, all 8 screws must be installed.

THIRD ATTEMPT

-  RAFTER
-  RAFTER HIT
-  RAFTER MISS

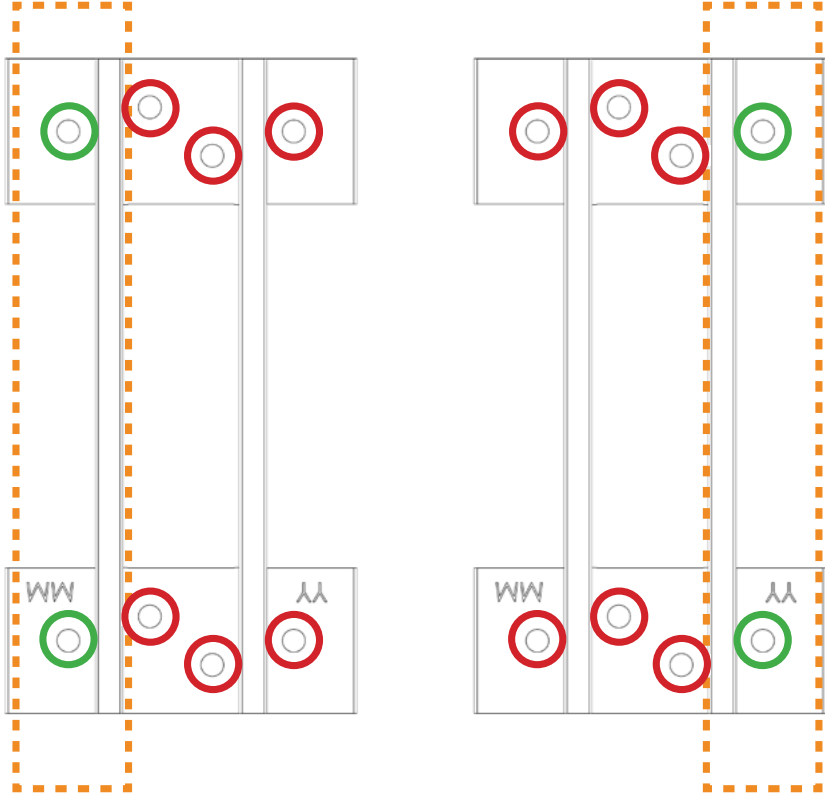

4. INSTALLATION - FOURTH ATTEMPT

If the rafter is missed completely within the slide, you must add another slide to the previous rafter. You may then continue with your job specific attachment spans.

FOURTH ATTEMPT

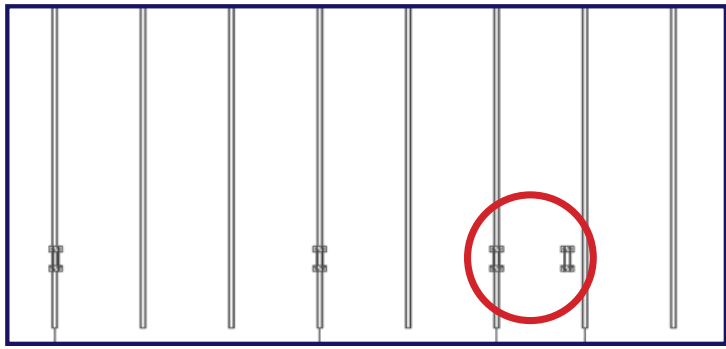

INSTALLATION

COMP SHINGLE INSTALLATION SMART SLIDE

COMPOSITION SHINGLE INFORMATION

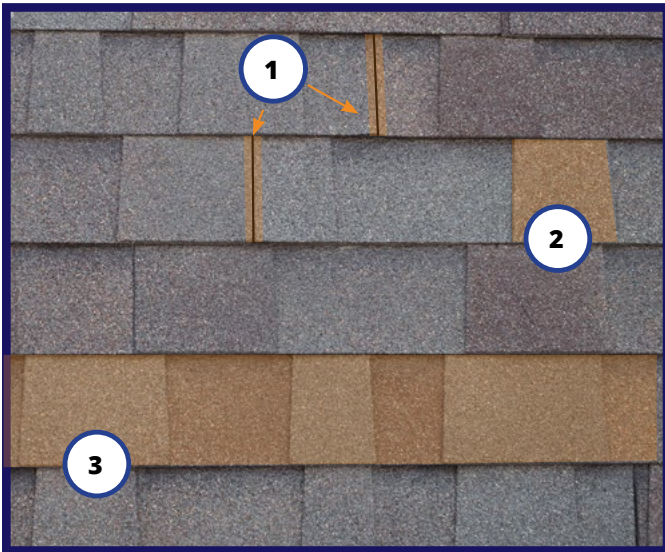

- ① **SHINGLE BUTT JOINT***
- ② **SHINGLE STEP**
- ③ **SHINGLE COURSE**

*Composition shingles either come in 36" or 1M length sheets. a butt joint is Where two adjacent sheets come together in a course.

SHINGLE BUTT JOINTS

Apply a bead of roof sealant over any exposed shingle butt joints north (upslope) of a mounting foot. Please reference our approved sealant list posted on our website.



SYSTEM INSTALLATION

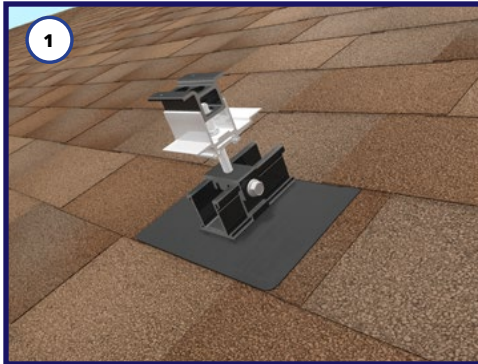

1 MOUNTS & ALIGNMENT

- Begin with the row that will get Skirt which is usually the far south row. On the far east and far west Slides, install a Mount about ½" from the south end of the Slide.
- Tighten side bolts to 200 in-lbs.
- Run a string line across the north edge of the base of the two Mounts.
- Add a Mount to each of the other Slides, position them up against the string line, and tighten the side bolts to 200 in-lbs.



2 SKIRT POSITION

- Rotate the top of the Mount so that the long, stepped shelf is facing north. Depending on the PV module thickness, use the appropriate A, B, or C Skirt.
- Set the Skirt on the south side of the Mount as shown.

TOP POSITION

40mm A SKIRT

38mm B SKIRT

CHANNEL POSITION

35mm A SKIRT

32mm B SKIRT

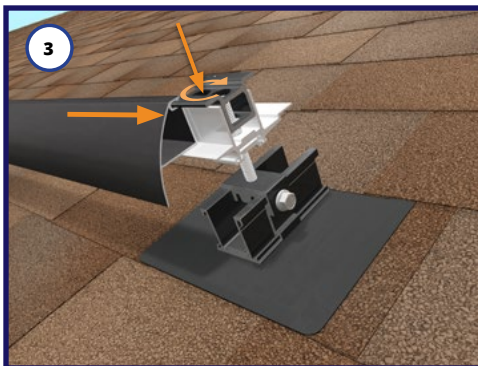

3 SKIRT TIGHTENING

Tighten top bolt in Mount to secure the Skirt

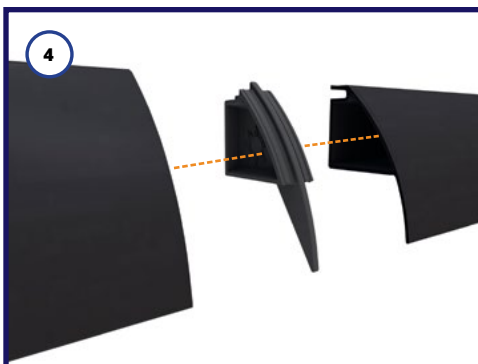

4 SKIRTS END CAPS

Press fit End Caps at every Skirt connection and on the ends.

NOTE: The End Caps makes it easier to align the Skirts and is required for strength.

SYSTEM INSTALLATION

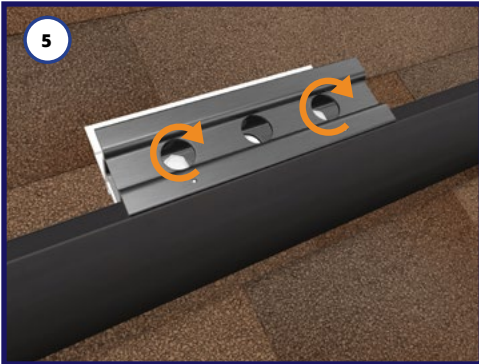

5 COUPLINGS ON SKIRTS

- Everywhere two modules will meet, install a Coupling on the Skirt with the long, stepped shelf facing north.
- Torque to 200 in-lbs.

NOTE: There must be at least one Mount or one Coupling connecting every Skirt section.

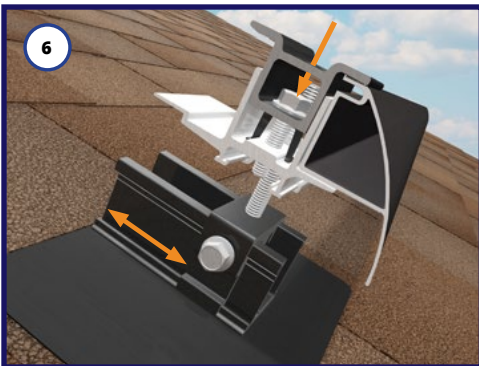

6 ALIGN & STRAIGHTEN SKIRTS (OPTIONAL)

- If the row of Skirts is not straight in the north-south direction, loosen appropriate side bolts, slide the Mount and retighten to 200 in-lbs
- If the row of Skirts is not straight in the up-down direction, adjust the leveling nut inside the Mount
- Align skirts with module edge



7 INSTALL FIRST ROW OF PV MODULES

- Place the modules into the first row of Mounts and Couplings at a 45 degree angle. While applying pressure against the Mounts and Couplings, lower the modules until parallel to the roof ensuring the modules are fully seated.
- Space the modules in the east/west direction $\frac{1}{2}$ " to $\frac{3}{4}$ ".

SYSTEM INSTALLATION



9 INSTALL SECOND ROW OF COUPLINGS

- At the intersection of the north side of two modules, install a Coupling with the two bonding pins facing south.
- Coupling can be positioned off center to avoid running into a Mount, but the two bonding pins must clamp different modules.
- Torque to 200 in-lbs.

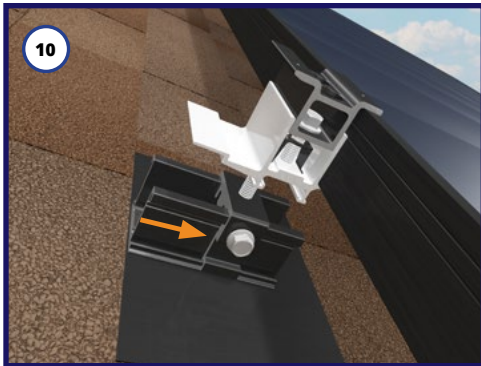

10 INSTALL SECOND ROW OF MOUNTS

- Lift the modules slightly and install the Mounts on the Slides to engage the north side of the module.
- Tighten to 200 in-lbs.

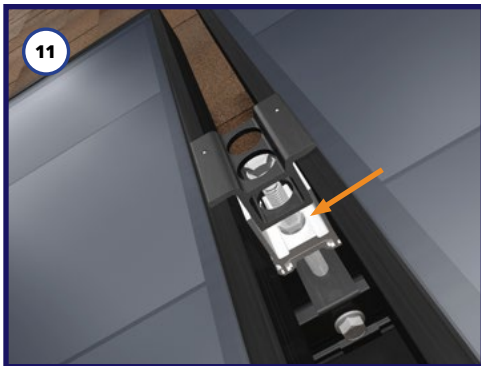

11 LEVELING (OPTIONAL) & WIRE MANAGEMENT

- Before installing next row of modules, level the row (if needed) by turning the leveling nut.
- Manage wires after each row of modules is installed (see Tips & Tricks video on wire management on the EcoFasten website)

12 COMPLETE THE ARRAY

Repeat steps above for all other rows in the array.



OTHER INSTALLATION OPTIONS

SUPPLEMENTAL GUIDES

ROOF ATTACHMENTS

SIMPLEBLOCK-U INSTALLATION

[Click here to view guide](#)

SIMPLEGRIP INSTALLATION

[Click here to view guide](#)

ACCESSORIES

CONDUIT MOUNT INSTALLATION

[Click here to view guide](#)

FRAME MLPE INSTALLATION

[Click here to view guide](#)

J-BOX INSTALLATION

[Click here to view guide](#)

BONDING AND GROUNDING

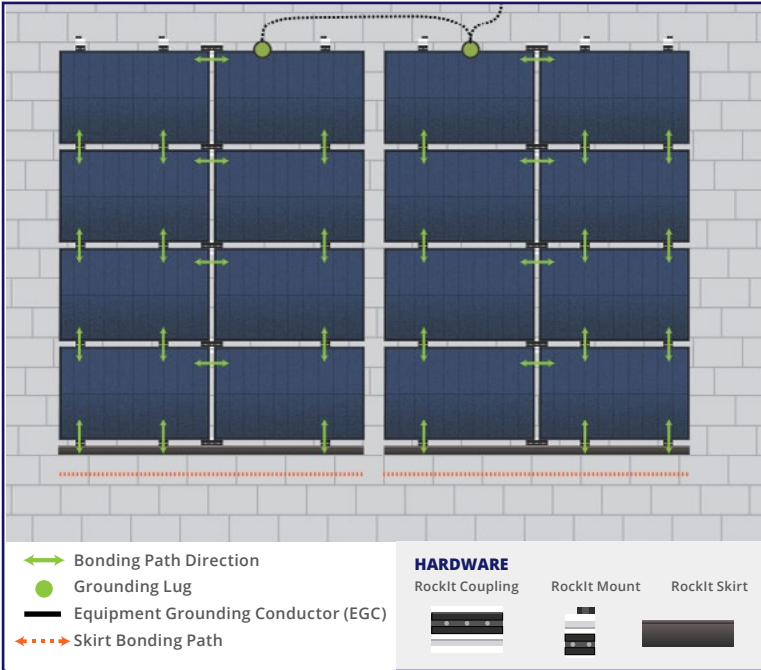

THERMAL EXPANSION & BONDING

- A thermal expansion gap is required per each continuous 70' length of modules.
- Omit a coupling and leave a 2" gap in the RockIt array skirt and also between the modules at that point.
- Bonding across the thermal gap should be accomplished with an approved ground lug for each array and an equipment grounding conductor.

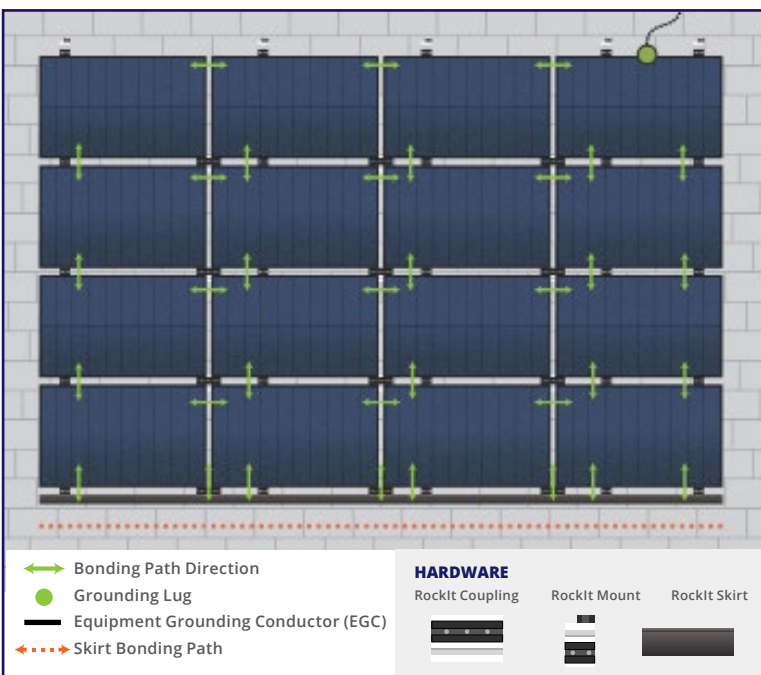

BONDING PATH & ASSEMBLY

- RockIt mount bonds North-South rows of modules.
- RockIt coupling bonds East-West rows of modules.
- RockIt array skirt is bonded to the array via the RockIt mount.
- One approved ground lug is required per continuous PV array.
- Ilco SGB-4 Approved for Mounting to Rockit Mount or Rockit Slides as alternate grounding location

GROUNDING

BONDING AND GROUNDING

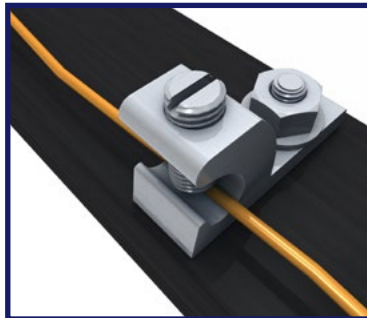

NECESSARY COMPONENTS

One of the following grounding lugs (or any UL 2703 Compliant ground Lug):

Burndy	CL50-1TN Ground Lug (UL2703 - E3514343 / UL 467 - E9999)
ILSCO	<ul style="list-style-type: none"> • GB-4 Ground Lug (UL2703 - E354420/ UL 467 - E34440) • GBL-4DBT (UL2703 - E354420 / UL 467 - E34440) • GBL-4DBTH (UL2703 - E354420 / UL 467 - E34440) • GBL-4SS (UL2703 - E354420 / UL 467 - E34440)

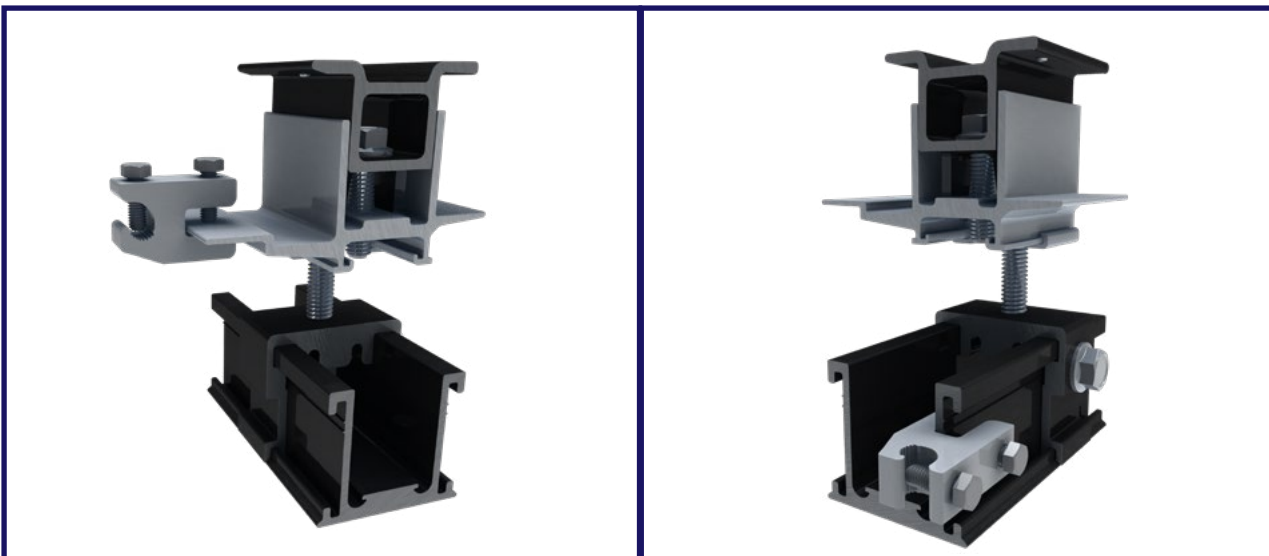

Above: Optional Locations for grounding lug on last row upslope of array

**Equipment grounding wire should be sized in accordance with the National Electrical Code, NFPA70 and a minimum of 1/4" clearance is required between bare copper wires and aluminum components.*

COMPATIBLE MODULES

The Rockit System has been tested and evaluated to UL 2703 for bonding, grounding, mechanical loading and fire classification, and may be used to ground and/or mount PV modules listed to UL 1703 or UL 61730. A list of approved modules is included below.

Unless otherwise noted, “xxx” refers to the module power rating and both black and silver frames are included in the certification.

NOTE: Modules with flange widths shorter than 22mm cannot be installed in portrait.

TYPE 1, 2, 3, 13, 19, 25, 29, 30 AND 38 MODULES

MANUFACTURER	LIST OF UL 2703 APPROVED PV MODULES*
Adani	Adani modules with 30, 35 and 40 mm frames ASX-Y-ZZ-xxx Where “X” can be B, M or P, “Y” can be 6 or 7, and “ZZ” can be blank, PERC, B-PERC, or AB-PERC
AIONRISE	Aionrise modules with 35 and 40 mm frames AIONyyG1-xxx Where “yy” can be 60 or 72
Aptos Solar	Aptos modules with 35 and 40 mm frames DNA-yy-zzaa-xxx Where “yy” can be 108, 120 or 144; “zz” can be BF, BFN, MF or MFN; “aa” can be 10, 23 or 26;
Astronergy Solar	Astronergy modules with 35 and 40 mm frames CHSMbbyyC/zz-xxx Where “bb” can be 60, 66, or 72; “yy” can be blank, 10 or 12; “C” can be M, M(BL), M-HC, P, P(BL) or P-HC ; and “zz” can be blank or HV
Auxin	Auxin modules with 40 mm frames AXNYMzYYMxxxB Where “Y” can be 6 , 10 or G1; “z” can be blank or 6; “YY” can be blank, 10 or 12; “B” can be blank, A, B, C or W
Axitec	Axitec Modules with 30 and 35 mm frames AC-xxxY/aaZZ “Y” can be M, P, MH, MBT or TGB; and “aa” can be blank, 125 or 156; and “ZZ” can be 60S, 108BB, 108BB-US, 108V, 108VB, 120S, 120V or 120VB



MANUFACTURER	LIST OF UL 2703 APPROVED PV MODULES*
Bluesun Solar	Bluesun modules with 30 and 35 mm frames BSMxxxM-AAA Where "AAA" can be 60HPH or 72HBD
Boviet	Boviet modules with 35 and 40 mm frames BVMZZaaYY-xxxBcc Where "ZZ" can be 66 or 76; "aa" can be 9, 10 or 12; "YY" is M, or P; and "B" can be blank, L or S; and "cc" can be blank, H, H-BF, H-HC or HC-BF
Canadian Solar	Canadian Solar modules with 30, 35 and 40 mm frames CSbY-xxxZ Where "b" can be 1, 3, 6, 6.1 or 6.2; "Y" can be H, K, L, N, P, R, V, Y, -48TD, -48TM or -54TM; and "Z" can be H, M, MS, M-SD, MS-HL, MS-SD, P, PX, or P-SD
CertainTeed	CertainTeed modules with 30, 35 and 40 mm frames CTBBxxxYZZ-AA Where "BB" can be blank, M10 or TC; "Y" can be M or HC; "ZZ" can be 00, 10, 11 or 12; and "AA" can be 04, 06, 08 or 09
Crossroads Solar	Crossroads Solar modules with 40 mm frames Crossroads Solar xxx
CSUN	CSUN modules with 35 and 40 mm frames CSUNxxx-zzAbb Where "zz" is 60 or 72; and "A" is M or MM; "bb" is blank or 5BB
Dehui	Dehui modules with 35 and 40 mm frames DH-MYYYY-xxx Where "YYYY" can be 760, 772, 860, 872; and "Z" can be B or W
Emmvee	Emmvee modules with 35 mm frames Exxx-YYZZZ-A Where "YY" can be HCM, HCMW, HCBT; "ZZZ" can be 108, 120 or 132; and "A" can be T or BT
Energy America	Energy America modules with 40 mm frames EA-ZLK7-SHDB108-xxx/M
ET Solar (EliTe Solar)	ET Solar modules with 30, 33, 35 and 40 mm frames ET-YZZZxxxAA Where "Y" can be P, L, M, N or NR; "ZZZ" can be 48TBH, 660, 660BH, 672, 672BH, 754BH, 760BH, 766BH, 760TBH, 766TBH or 848TBH; and "AA" can be GB, GL, TB, TW, WB, WW, BB, WBG, WWG, WBAC, WBCO, WWCO, WWB-CO or BBAC



MANUFACTURER	LIST OF UL 2703 APPROVED PV MODULES*
Freedom Forever	Freedom Forever modules with 35 mm frames FF-MPa-BBB-xxx Where "a" can be blank or 1
Freevolt	Freevolt modules with 35 mm frames ECP-PVGRAF-144HC-xxx
Goldi	Goldi modules with 35 mm frames GS10-B108-TF-xxx
Grape Solar	Grape modules with 35 mm frames GS-M120-xxx-FAB1
GreenWatts Solar	GreenWatts modules with 30 and 35mm frames HSYY-A-xxx-ZZ Where "YY" can be 54, 60 or 66; "A" can be blank or F; and "ZZ" can be MN or BOB
Hansol	Hansol modules with 30 mm frames HAxxxYY-ZZZ Where "YY" can be AA, AB or XA; and "ZZZ" can be CGEA0, DGEA0, NGEA0, NNEA0
Heliene	Heliene modules with 35 and 40 mm frames YYZZxxxA Where "YY" can be 60, 72, 108, 120 or 132; "ZZ" can be HC, M or P; and "A" can be blank, M10-SL, M10 TPC SL, M10-SL-BLK, M10-SL-Bifacial or M10 NTYP SL
HT-SAAE	HT-SAAE modules with 35 and 40 mm frames HTyy-aaaZ-xxx Where "yy" can be 60, 66 or 72, "aaa" can be 156 or 166, "Z" can be M, M(V), M(S), M(VS), M-C, M(V)-C, P or P(V)
Hyperion Solar (Runergy)	Hyperion or Runergy modules with 35 mm frames HY-DH108Y8-xxxB Where "Y" can be N or P; and "B" can be blank or B
Hyundai	Hyundai modules with 30, 32, 35 and 40 mm frames HiY-SxxxZZ Where "Y" can be A, N or S; "S" can be M, S or T; and "ZZ" can be HG, KI, MF, MG, NF(BK), OJ, PI, SG, RG, RG (BK), TG or YH(BK) or XG(BK)
Imperial Star	Imperial Star Modules with 35 mm frames ISY7-zzz108-xxx/M Where "Y" can be M or N; "zzz" can be SHSB or UHSB
Itek	Itek Modules with 40 mm frames IT-xxx-YY "YY" can be blank, HE, or SE



MANUFACTURER	LIST OF UL 2703 APPROVED PV MODULES*
JA Solar	JA Solar modules with 30, 35 and 40 mm frames JAyyzz-bbww-xxx/aa Where “yy” can be M, P, M6 or P6; “zz” can be blank, (K), (L), (R), (V), (BK), (FA), (SE), (TG), (FA)(R), (K)(SE), (K)(TG), (L)(BK), (L)(TG), (R)(BK), (R)(TG), (V)(BK), (BK)(TG), or (L)(BK)(TG); “bb” can be 54, 60 or 72; “ww” can be blank, D30, D41, S01, S02, S03, S09, S10, S17, S30 or S31; and “aa” can be MB, MR, SI, SC, PR, RE, 3BB, 4BB, 4BB/RE, 4BB/1500V, PR/1500V, 5BB
Jinko	Jinko modules with 30, 35 and 40 mm frames JKMYxxxZZ-aa Where “Y” can either be blank or S; “ZZ” can be M, N, P, PP, or -V; and “aa” can be blank, 54HL4-B, 60, 60B, 60H, 60HB, 60L, 60BL, 60HL, 60HBL, 60-J4, 60B-J4, 60B-EP, 60(Plus), 60-V, 60-MX, 72H, 72H-V, 72HL-V, 72HBL-V, 72L-V, 6RL3, 6RL3-B or 6TL3-B
Jolywood Solar	Jolywood Solar modules with 30mm frames JW-HDYNN-ZZ-xxx Where “YY” can be 96 or 108; and “ZZ” can be blank, R0 or R2
KB Solar	KB Solar modules with 35 mm frames KBS-xxx-Mono-YY Where “YY” can be blank or BF
LA Solar	LA Solar modules with 35 mm frames LSxxxYY Where “YY” can be BL, BLA, HC or ST
LG	LG modules with 40 mm frames LGxxyyaz-bb “y” can be A, E, M, N, Q, or S; “a” can be A, 1, 2 or 3; “z” can be C, K or W; and “bb” can be G4, A5, A6, B6, E6, E6.AW5, L5, N5, v5, V6
Longi	Longi modules with 30, 35 and 40 mm frames LRa-YYZZ-xxxM Where “a” can be 4, 5, 6, 7 or 8; “YY” can be 54, 60 or 66 “ZZ” can be blank, BK, PB, PE, PH, HPB, HPH, HABB, HABD or HGBB
Maxeon	Maxeon modules with 35, 40 and 46 mm frames SPR-AAAY-xxx-zzz Where “AAA” can be MAX or X; “Y” can be 3, 5, 6, 7, 21 or 22; and “zzz” can be blank, R, BLK, BLK-R or COM
Meyer Burger	Meyer Burger Modules with 35 mm frames Meyer Burger Black, White or Glass



MANUFACTURER	LIST OF UL 2703 APPROVED PV MODULES*
Mission Solar (mSolar)	Mission Solar modules with 35, 40 mm frames YYYbb-xxxZZaa Where "YYY" can be MSE, MSX, TXI or TXS; "bb" can be blank, 6, 10 or 60A; "ZZ" can be blank, HN, HT, SO, SQ, SX, 108, 120 or 144; and "aa" can be blank, 0B, 2B, BB, BW, 4J, 4S, 5K, 5R, 5T, 8T, 8K, 9R or 9Z
Mitrex	Mitrex modules with 30, 35 and 40 mm frames Mxxx-XYZ Where "X" can be A, B, I or L; "Y" can be 1 or 3; and "Z" can be F or H
Next Energy Alliance	Next Energy Alliance modules with 35 and 40 mm frames yyNEA-xxxZZ where "yy" can be blank or US; "ZZ" can be M, MB or M-60
NE Solar	NE Solar modules with 30, 35 and 40 mm frames NESExxx-zzMHX-yy Where "zz" can be 54, 60 or 72; "X" can be blank or B; and "yy" can be M6 or M10
Panasonic (HIT)	Panasonic modules with 40 mm frames VBHNxxxYYzzA "YY" can be either SA or KA; "zz" can be either 03, 04, 17 or 18; and "A" can be blank, E or G
Panasonic (EverVolt)	Panasonic modules with 30 mm frames EVPVxxxA Where "A" can be blank or H, K, HK, HK2 or PK
Philadelphia Solar	Philadelphia modules with 30, 35 and 40 mm frames PS-YzzAA-xxxW Where "Y" can be M, MNB, MNG or P; "zz" can be 60, 72, 108, 132 or 144; "AA" can be blank, (BF), (HC) or (HCBF); and "W" can be blank or W
Phono Solar	Phono Solar modules with 30 and 35 mm frames PSxxxY-ZZ/A Where "Y" can be M4, M4H, M5GF, M5GFH, M6, M6H, M8GF or M8GFH; "ZZ" can be 18, 20 or 24; and "A" can be TH, UHB, VH, VHB or VNHB
Prism Solar	Prism Solar modules with 35 mm frames PST-xxxW-M72Y Where "Y" can be H, HB or HBI



MANUFACTURER	LIST OF UL 2703 APPROVED PV MODULES*
Q CELLS	Q CELLS Modules with 30, 32, 35 and 40 mm frames aaYY-ZZ-xxx where "aa" can be Q. or B.; "YY" can be PLUS, PRO, PEAK, LINE PRO, LINE PLUS, PLUS DUO, PEAK DUO or Tron; and "ZZ" can be G3, G3.1, G4, G4.1, L-G2, L-G2.3, L-G3, L-G3.1, L-G3y, L-G4, L-G4.2, L-G4y, LG4.2/TAA, BFR-G3, BLK-G3, BFR-G3.1, BLK-G3.1, BFR-G4, BFR-G4.1, BFR G4.3, BLK-G4.1, G4/SC, G4.1/SC, G4.1/TAA, G4.1/MAX, BFR G4.1/TAA, BFR G4.1/MAX, BLK G4.1/TAA, BLK G4.1/SC, EC-G4.4, G5, G5/SC, G5/TS, BLK-G5, BLK-G5/SC, BLK-G5/TS, L-G5, L-G5.1, L-G5.2, L-G5.2/H, L-G5.3, L-G6.3/BFG, G6, G6/SC, G6/TS, G6+, G6+/TS, BLK-G6, G7, BLK-G6+, BLK-G6+/AC, BLK-G6+/HL, BLK-G6+/SC, BLK-G6/TS, BLK-G6+/TS, BLK-G7, G7.2, G8, BLK-G8, G8+, BLK-G8+ L-G7, L-G7.1, L-G7.2, L-G7.3, M-G2+, BLK M-G2+, BLK M-G2.C+, BLK M-G2.F+, BLK M-G2.H+, BLK M-G2+/AC, BLK M-G2.C1+/AC, BLK M-G2.F1+/AC, BLK M-G2.H1+/AC, BLK ML-G9, ML-G9+, BLK ML-G9+, ML-G9, BLK-G10, BLK-G10+, BLK-G10+/AC, ML-G10, BLK ML-G10, ML-G10+, BLK ML-G10+, ML-G10.a, BLK ML-G10.a, ML-G10.a+, BLK ML-G10.a+, BLK ML-G10.B+, BLK ML-G10.C+, BLK ML-G10.C1+/AC, BLK ML-G10 +/t, BLK-G10+/HL and BLK ML-G10+/TS
REC	REC modules with 30 and 38 mm frames RECxxxYYZZ Where "YY" can be AA, M, NP, NP2, NP3, PE, PE72, TP, TP2, TP2M, TP2SM, TP2S, TP3M or TP4; and "ZZ" can be blank, Black, BLK, BLK2, SLV, 72, Pro M, Pure, Pure-R, Pure-RX or Pure 2
Recom	Recom modules with 35 and 40 mm frames RCM-xxx-6yy Where "yy" can be MA, MB, ME or MF
Renesola	ReneSola 60-cell modules with 40 mm frames JCxxxY-ZZ "Y" can be F, M or S; and "ZZ" can be Ab, Ab-b, Abh, Abh-b, Abv, Abv-b, Bb, Bb-b, Bbh, Bbh-b, Bbv, Bbv-b, Db, or Db-b
Renogy	Renogy Modules with 35 mm frames RSPxxxD-YY-ZZZ Where "YY" can be BB or BK; and "ZZZ" can be blank, 108 or 120
S-Energy	S-Energy modules with 35 and 40 mm frames SABB-CCYYY-xxxZ Where "A" can be C, L or N; "BB" can be blank, 20, 40 or 45; "CC" can be blank, 60 or 72; "YYY" can be blank, MAE, MAI, MBE, MBI, MCE or MCI; and "Z" can be V, M-10, P-10 or P-15



MANUFACTURER	LIST OF UL 2703 APPROVED PV MODULES*
Seraphim	Seraphim modules with 30, 35 and 40 mm frames SRP-xxx-YYY-ZZ Where "YYY" can be 6MA, 6MB, 6PA, 6PB, BMD, BTD or BTE; "ZZ" is blank, BG or HV
SEG Solar	SEG Solar Modules with 30, 35 and 40 mm frames SEG-xxx-YYY-ZZ Where "YYY" can be BMB, BMD, BTB, BTD or 6MA; "ZZ" can be BB, BG, BW, HV, TB, WB or WW
Shinsung E&G	Shinsung Modules with 35 mm frames SSVxxx-144MH
Silfab	Silfab Modules with 35 and 38 mm frames SYY-Z-xxxAb Where "YY" can be IL, SA, LA, SG or LG; "Z" can be blank, M, P, or X; "A" can be blank, B, H, M, N, Q or X; and "b" can be A, C, C+, D, G, K, L, M, N, T, U or X
Sinotec	Sinotec Modules with 30 mm frames STS-xxxP-54DD
Sirius PV	Sirius PV Modules with 35 mm frames ELNSM54M-HC-yy-xxx Where "yy" can be BF or N
Solar4America	Solar4America modules with 30, 35 and 40 mm frames S4Axxx-ZZyyAA Where "ZZ" can be 60, 72 or 108; "yy" can be MH5, MH10 or TH10; and "AA" can be blank, BB, BW or SW
Solarever	Solarever modules with 30, 35 mm frames SE-zzz*yy-xxxM-aaa Where "zzz" can be 166 or 182; "yy" can be 83, 91 or 105; and "aaa" can be 96-BD, 108 or 144
Solaria	Solaria modules with 35 and 40 mm frames PowerA-xxxR-ZZ Where "A" can be XT or X; and "ZZ" can be blank, AC, BD, BX, BY, PD, PL, PX, PZ, WX or WZ
SolarSpace	SolarSpace modules with 30 mm frames SS8-54zzz-xxxA Where "zzz" can be HDB or HSB; and "A" can be M or N
SolarTech	SolarTech modules with 40 mm frames AAA-xxx Where "AAA" can be PERCB-B, PERCB-W, HJTb-B or HJTb-W



MANUFACTURER	LIST OF UL 2703 APPROVED PV MODULES*
Sonali	Sonali Modules with 35 and 40 mm frames SS-M-xxx-yyy Where "M" can be blank or M; and "yyy" can be blank or W-M60H M10
Star Solar	Star Solar modules with 35 mm frames Star-xxxYYY-ZZZ Where "YYY" can be M60H or M60HB; and "ZZZ" can be blank or M10
Sunmac Solar	Sunmac modules with 30 and 35 mm frames SMxxxMaaaZZ-BB Where "aaa" can be 660 or 754; and "ZZ" can be NH or SH
Sunpower	Sunpower modules with 35 and 40 mm frames SPR-A-xxx-YY Where "A" can be A or M; and "YY" can be blank, COM, G-AC, BLK-G-AC, H-AC or BLK-H-AC
Sunpreme	Sunpreme Modules with 40 mm frames GxB-xxxT
Sunpro	Sunpro Modules with 30 mm frames SPDGxxx-N108M10
Sunspark	Sunspark modules with 40 mm frames SYY-xxxZ-A Where "YY" can be MX or ST; and "Z" can be M, MB, M3, M3B, P or W; and "A" can be 60 or 72
Suntech	Suntech Modules with 35 mm frames STPxxxS-zz/aa Where "zz" can be B60 or B72; and "aa" can be Vnh or Wnhb
Talesun	Talesun modules with 30 and 35 mm frames TAByZZA-xxx Where "A" can be D, M or P; "B" can be 3, 6, 7 or 9; "y" can be G, I or L; "ZZ" can be 48, 54, 60 or 72; and "A" can be M or M(H)
Tesla	Tesla modules with 40 mm frames TxxxY Where "Y" can be H or S
Thornova	Thornova Modules with 30 and 35 mm frames TS-YYZZ(XXX)-X Where "YY" can be BB, BBT, BG or BGT; "ZZ" can be 54 or 60; and "X" can be blank, G11 or X
Topco Solar	Topco Solar modules with 30mm frames TPM7-SH108-xxx/M



MANUFACTURER	LIST OF UL 2703 APPROVED PV MODULES*
Trina	Trina modules with 30, 35 and 40 mm frames TSM-xxxYYZZ "YY" can be DD05, DD05A, DD06, DE05, DE09, DX05A, DE06X, PA05, PC05, PD05, PE14, PX05, NE09RC or NE09RH.05; and "ZZ" can be blank or A, .05, .05(II), .08, A.05, A.08, A(II), A.05(II), A.08(II), C.05, C.07, C.05(II), C.07(II), H, H.05, H.08, H.05(II), H.08 (II), M, M(II) or M.05(II)
Universal	Universal Solar Modules with 35 mm frames UNI-xxx-yyyZZZ-aa Where "yyy" can be 108, 120 or 144; "ZZZ" can be M, MH or BMH; and "aa" can be blank, BB or DG
URE	URE modules with 30 and 35 mm frames DyMxxxaa Where "D" can be D or F, "y" can be A, B, 6 or 7; "M" can be F, K, or M; and "aa" can be BFG, B7G, BFG-BB, DFG-BB, C8G, H3A, H4A, H8A, E7G-BB, MFG, MFG-BB or M7G-BB
Vikram	Vikram solar modules with 35 and 40 mm frames XVSyy.ZZ.AAA.bb Where "X" can be blank, Paradea, Prexos or Somera; "yy" can be MDH, MDHT, MH or MHBB; "ZZ" can be 54, 60 or 72; "AAA" is the module power rating; and "bb" can be 05
VSUN	VSUN modules with 30, 35 and 40 mm frames VSUNxxxB-YYz-aa Where "B" can be blank or N; "YY" can be 96, 108 or 120; "z" can be BMH, BMHR, BMHS or M; and "aa" can be blank, BB, BW, DG, DG-BB or DG-BT
Waaree	Waaree modules with 35 and 40 mm frames WSy-xxx where "yy" can be blank, M, MB, MDI or MDIB
Yingli	Yingli modules with 30, 35 and 40 mm frames YLxxxZ-yy Where "Z" can be D or P; "yy" can be blank, 29b, 30b, 34d, 35b, 36b, 37e 1/2, 37e 1500V 1/2, 40d, 49e 1/2 or 49e 1500V 1/2
Yotta	Yotta modules with 30 mm frames YSM-Bxxx-06-72-1
Zeus	Zeus Solar Modules with 40 mm frames ZxxxM-HB
ZN Shine	ZN Shine modules with 30 or 35mm frames ZXMY-AAA-xxx/M Where "Y" can be 6 or 7; "AAA" can be 72, NH120, NHDB144, SH108, SHDB120, SHLDD120 or UHLDD108; and "M" can be M or N

TYPE 4 MODULES

**Class A System fire rating with Steep Slope Roofs and Type 4 modules with south edge skirt required. Class B System fire rating with Steep Slope Roofs Type 4 modules, no skirt required. Any roof-to-module gap is permitted. This rating is applicable with any roof attachment.

MANUFACTURER	LIST OF UL 2703 APPROVED TYPE 4 PV MODULES**
Bluesun Solar	Bluesun modules with 35 mm frames BSMxxxM10-54HPH
Emmvee	Emmvee modules with 35 mm frames Exxx-YYZZZ-B Where "YY" can be M, P and HCM; "ZZZ" can be 72 or 120
Jakson Solar	Jakson Solar modules with 35mm frames JH-xxxYY Where "YY" can be BB or BT
Magnus Green Solar	Magnus Green Solar modules with 35 mm frames MGS-xxxW-yyy-M10 Where "yyy" can be M54H, M60H or M72H
Navitas	Navitas Modules with 35 mm frames NSMxxx-yyy Where "yyy" can be 120, 132 or 144
Peimar	Peimar modules with 35 mm frames DR10HxxxM
Saatvik	Saatvik Modules with 35 mm frames SGExxx-108ZZZ Where "ZZZ" can be MHC, MBHC or MHCB
Sinotec	Sinotec Modules with 30 and 35 mm frames STS-xxxP-aabb Where "aa" can be 54 or 72; and "bb" can be BB or DB
Sirius PV	Sirius PV Modules with 35 mm frames ELNSM54M-HC-xxx
Solarever	Solarever modules with 30, 35 mm frames SE-zzz*yy-xxxM-aaa Where "zzz" can be 166 or 182; "yy" can be 83 or 91; and "aaa" can be 120-BH or 144N
Solaria	Solaria modules with 35mm frames PowerX-xxxR-4T



MANUFACTURER	LIST OF UL 2703 APPROVED TYPE 4 PV MODULES**
Sonali	Sonali Modules with 35 mm frames SS-xxx-108M-B
Sungold	Sungold Modules with 35 mm frames SG-xxxWM
Sunspark	Sunspark Modules with 30mm frames SST7F54M(H)-xxx
Talesun	Talesun modules with 30 mm frames TP7G54M(H)xxx
Waaree	Waaree modules with 35 mm frames AAyy-xxx Where "AA" can be WS or Bi; and "yy" can be MD, MDI, MDIB, 33 or 57

ROCKIT

INSTALLATION GUIDE



FOR INSTALLERS. BY INSTALLERS.

Under the PanelClaw brand and Enstall's corporate umbrella, EcoFasten has established a reputation as one of the industry's leading innovators by providing expert solutions for mounting solar PV on any roof. EcoFasten's broad portfolio of solar rooftop mounting systems and attachments stems from the direct needs of solar PV installers. EcoFasten takes pride in providing the right solution for every application.



1295 W. WASHINGTON STREET, SUITE 110, TEMPE, AZ 85288
877-859-3947 | INFO@ECOFASTENSOLAR.COM | ECOFASTENSOLAR.COM